

hedley & bennett

DESIGNED & TESTED TO HANDLE THE HUSTLE

Welcome to the Apron Squad

LA-based and female founded, we outfit the best chefs and makers in the world.



EVERY APRON IS BUILT TO LAST



Adjustable straps & solid brass hardware

100% natural webbing from an American mill

All aprons are handmade with love in Los Angeles

Pockets reinforced with bar tacks to protect corners from ripping off

Over 400 fabric options, all stain & wash tested

40" straps so you can tie your apron any way you like

MEET OUR COLLECTIONS

We created five collections to help you choose the perfect apron to bring your brand, team and restaurant to life. This is about so much more than an apron - it's about dignity and pride in the kitchen and making your team look and feel awesome.

MINIMAL



NATURAL



INDUSTRIAL



BOLD

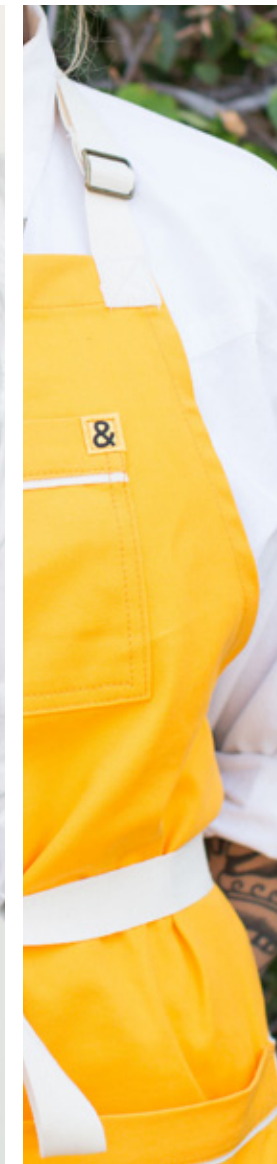

CLASSIC

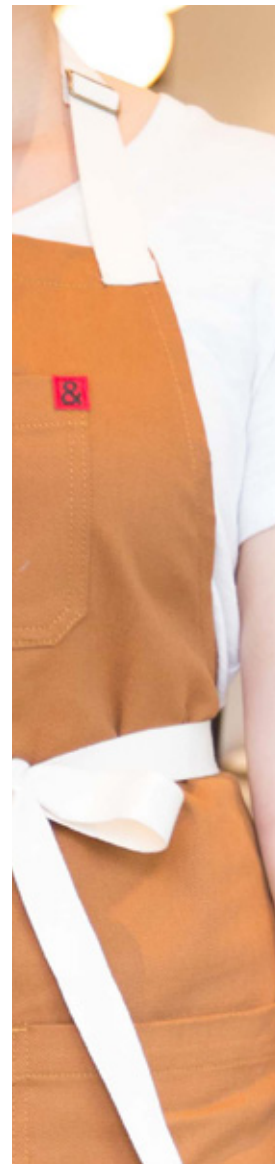

MINIMAL

CLEAN & SIMPLE

The Minimal Collection focuses on effortless in every detail. Enjoy comfort in your workspace with lightweight fabrics and crisp lines that boast versatility. No bold surprises, no gimmicks. Because understated makes the ultimate statement.



“

The aprons are a superior quality, beautifully designed & always a huge hit with both chefs and guests at our events!”

ADDIE SPECTOR
Alex's Lemonade



» VANILLA APRON



» NAVY APRON



» BLACK APRON



» BLACK BISTRO



» VANILLA APRON, BLACK APRON, BLACK BISTRO

NATURAL

SOFT & SUBTLE

Locally sourced, free range, wild-caught in every stitch. **The Natural Collection** combines earthy, neutral tones with utility and ease for a look that's on trend and comfort that's on point.

“

H&B aprons are the most thoughtfully designed in the game, from the materials to the details.”

HEATHER SPERLING
Botanica · Silver Lake, CA



»» WOODSTOCK APRON



»» NEW SMOCK FRONT



»» NEW BELL BISTRO SIDE



»» NEW SMOCK DETAIL



»» NEW BELL BISTRO



INDUSTRIAL

DURABLE & BADASS

The Industrial Collection is ready to get down and dirty. Made with our toughest leather, water-resistant materials, cross-back designs, loudest details and specialty embossing, there's nothing it can't handle. Pride is no longer worn on your sleeve. It's now on your apron.

“

The best apron I've ever worn!”

ALTON BROWN

Need more coverage?
Meet The Big



» BIG: OUR LONGER AND WIDER APRON

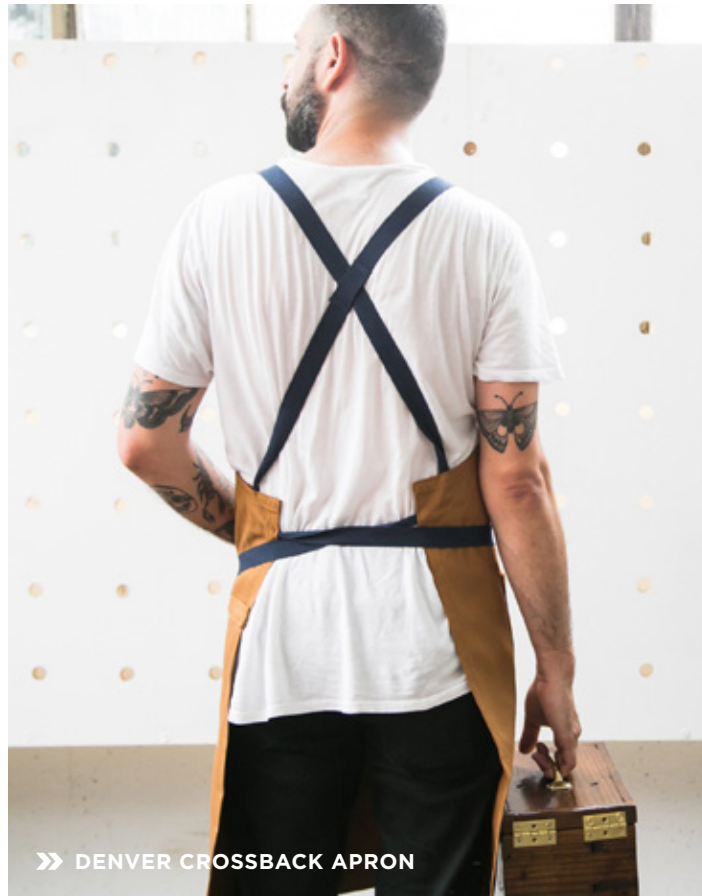

» DENVER CROSSBACK APRON



» HADDOCK CROSSBACK APRON



» ALDER APRON



» DENVER CROSSBACK APRON



BOLD

FIERCE & IMPACTFUL

The Bold Collection brings bright colors, whimsy and unique details to the table. This is your spot if you want to stand out and have fun.

“

In the past, any new uniform would always be received in some negative manner: Too itchy, too hard to clean, not flattering. I never put an associate in a new uniform that received such positive compliments.”

KEVIN GARVIN
VP, Corporate Food Services
Neiman Marcus



»» ROSÉ APRON



»» CANARY APRON



»» NOVA APRON



»» MINT APRON



»» ADELE APRON

CLASSIC

ORIGINAL & TIMELESS

Form meets function in this line, thoughtfully designed with your craft in mind. **The Classic Collection** is where it all started, with simple pockets and dark fabrics that hide stains easily, helping you get the job done. Quality stitching and structure make it so you never have to worry while you work.



At Tender Greens, we hire the best talent, source the best product and create the best versions of American classics. We wouldn't think to use anything other than the best apron... and that's why we love Hedley & Bennett."

DENYELLE BRUNO
President, Tender Greens



» DEARBORNE AVE APRON



» CIDER HOUSE APRON



» CHAR APRON



» MIDNIGHT APRON



» DASHI APRON

THE FULL BREAKDOWN

EVERY STYLE AND EVERY COLOR OF EVERY COLLECTION

CLASSIC



ABALONE ANIMAL CHAR CIDER HOUSE DASHI DEARBORNE AVE GINGER HICKORY



MICHAEL GRAY MIDNIGHT MR. CONE PHO SPINNING PLATES STRIPED BASS TRUFFLE TURBOT

BOLD

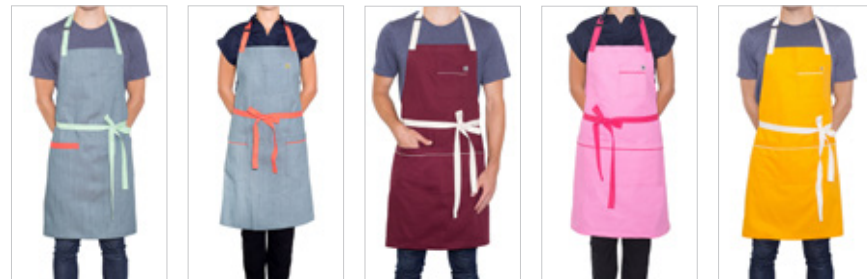

ADELE ADDY BORDEAUX BUBBLEGUM CANARY



KANPACHI MINT NOVA ROSE

MINIMAL



GRAY NAVY VANILLA BLACK BISTRO GRAY BISTRO NAVY BISTRO VANILLA BISTRO BLACK

INDUSTRIAL

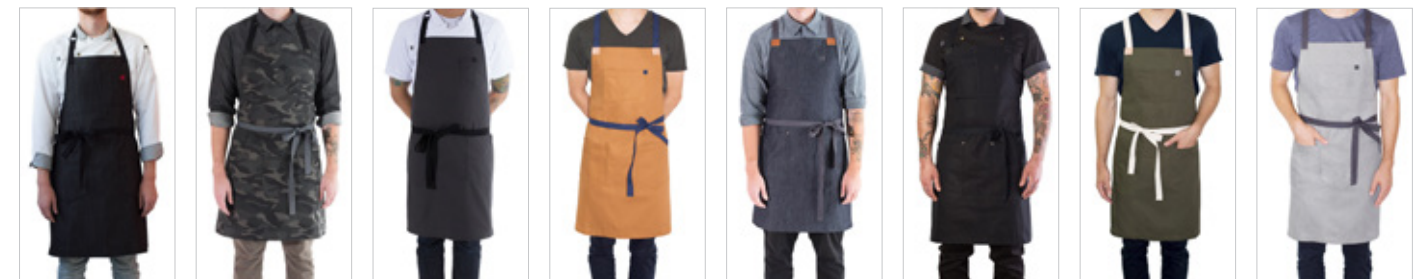

ABALONE ALDER CHAR DENVER CROSSBACK JACK CROSSBACK BLACKJACK CROSSBACK MOSS CROSSBACK HADDOCK CROSSBACK



SESAME NAVY WAX DENIM

NATURAL

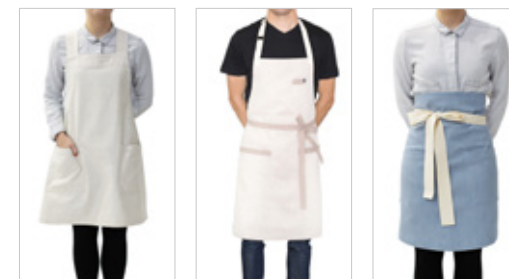

SMOCK VANILLA WOODSTOCK BELL BISTRO

LEGEND



MINI BISTRO CAFE BISTRO MINIMAL BISTRO CLASSIC BISTRO BELL BISTRO

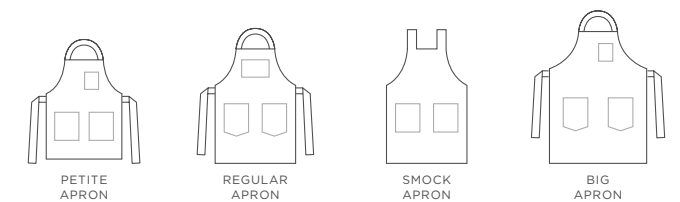

PETITE APRON REGULAR APRON SMOCK APRON BIG APRON

QUICK CUSTOM™

Customize our most popular apron in three simple steps. Minimum order of 25 aprons. Ships in two weeks. Starting at \$45.



“
It's your kitchen—you should have exactly what you want.
”
- ELLEN BENNETT

STEP 1

CHOOSE APRON FABRIC

STARTING AT \$45

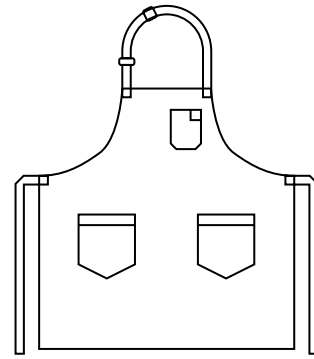

Regular-Style Apron
(cannot change)

POLY-COTTON BLEND • 50% polyester, 50% cotton blend • washer/dryer friendly • stain-resistant

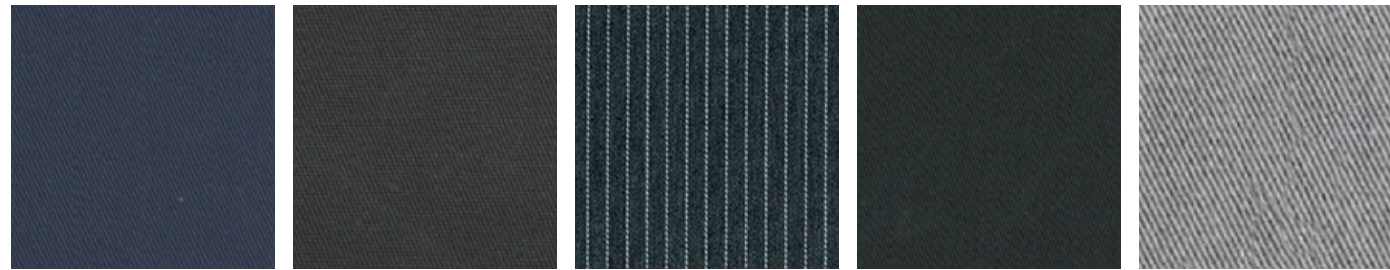

NAVY POLY

CHAR POLY

PINSTRIPED POLY

BLACK POLY

PHO POLY

CANVAS +\$5 • 100% cotton • medium-weight duck canvas • durable and machine washable

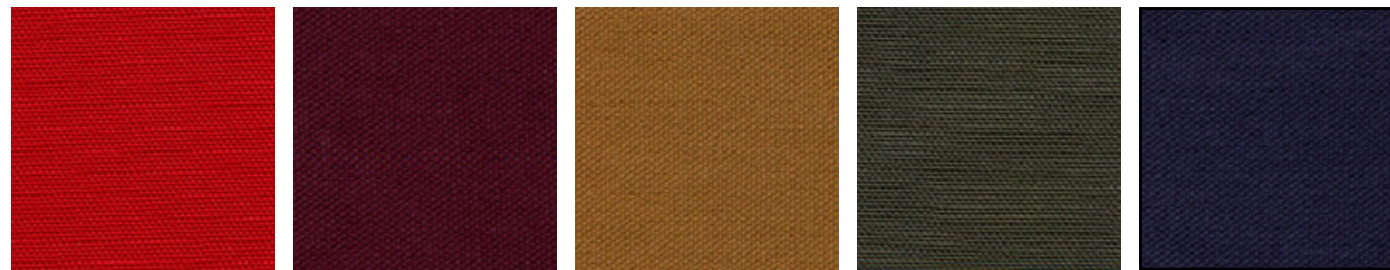

RED CANVAS

BURGUNDY CANVAS

DENVER CANVAS

MOSS CANVAS

NAVY CANVAS

DENIM +\$10 • cotton • medium to heavy weights • machine-wash cold with like colors only

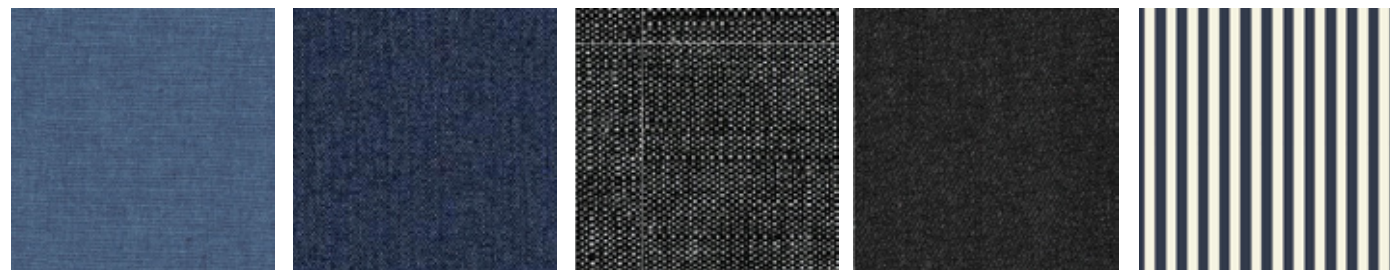

TURBOT

JACK

PEPPERCORN

ABALONE

HICKORY

STEP 2

CHOOSE STRAP COLOR



STEP 3

CHOOSE AMPERSAND COLOR



■ ADD-ONS

CROSSBACK STRAPS +\$10



FRONT

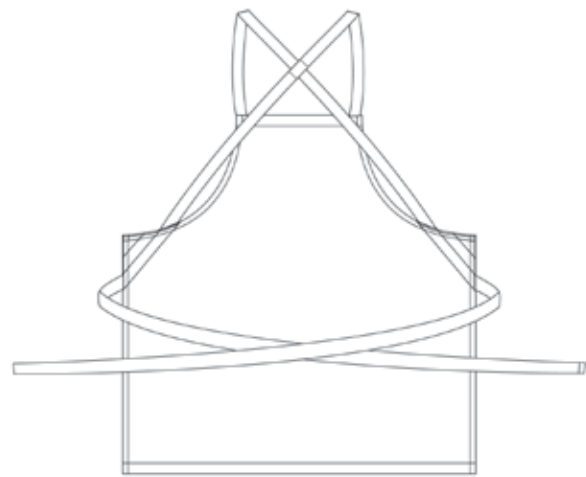

BACK

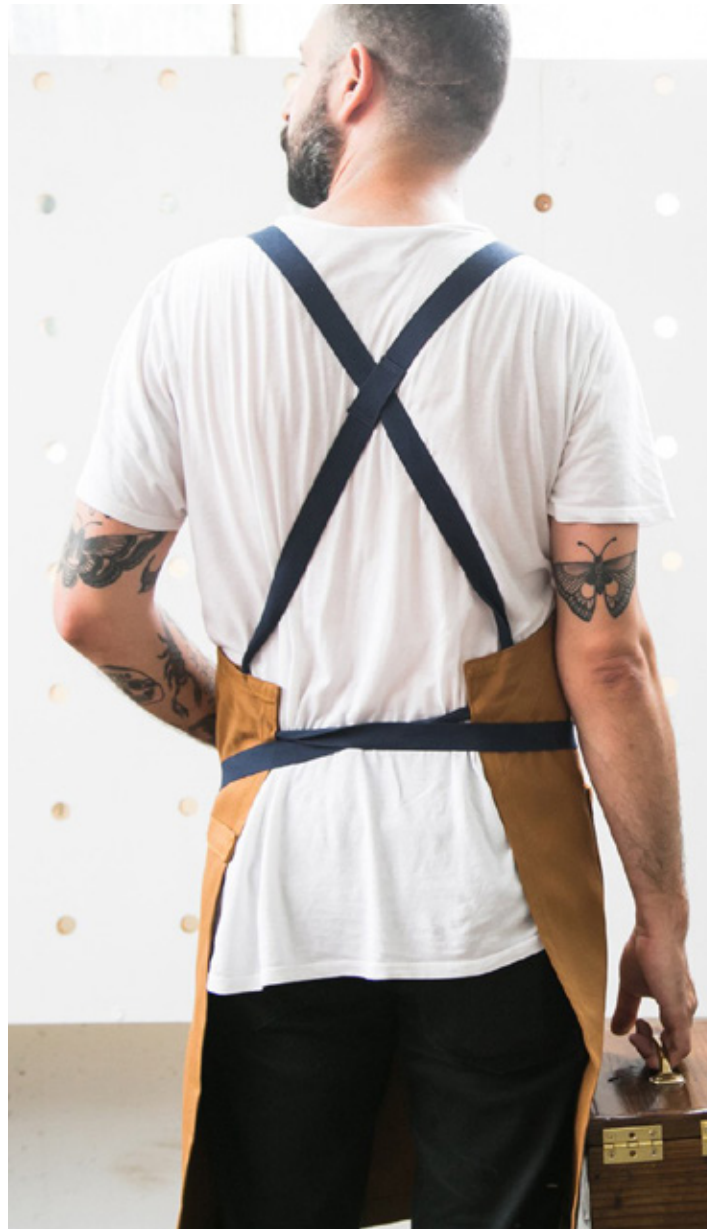

EMBROIDERY PLACEMENT

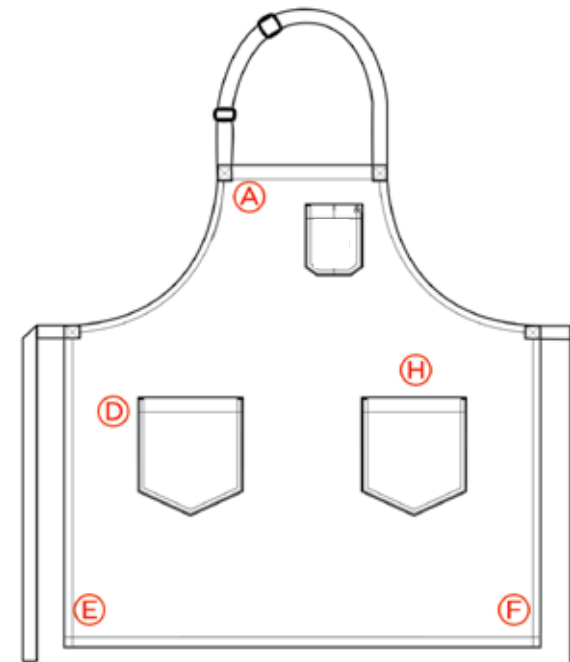

EMBROIDERY OPTIONS

BASIC +\$7

- Simple text or logo
- 1-2 colors
- Not filled in with color
- Smaller logos

DETAILED +\$9

- Minor details
- Multiple colors
- Not filled in with color
- Small to medium logos

INTRICATE +\$10 and up

- Fine details
- Lots filled in with color
- Multiple colors
- Medium to large logos

EMBROIDERY EXAMPLES

BASIC +\$7

RAINBOW
ROOM

DETAILED +\$9



INTRICATE +\$10 and up



NEED SOMETHING DIFFERENT?

START FROM SCRATCH

CUSTOM FROM START TO FINISH

\$250 DESIGN FEE
50 UNIT MINIMUM ORDER

•
any body apron
one-on-one design session
any pocket (or) towel loop



STEP 1 BODY TYPE

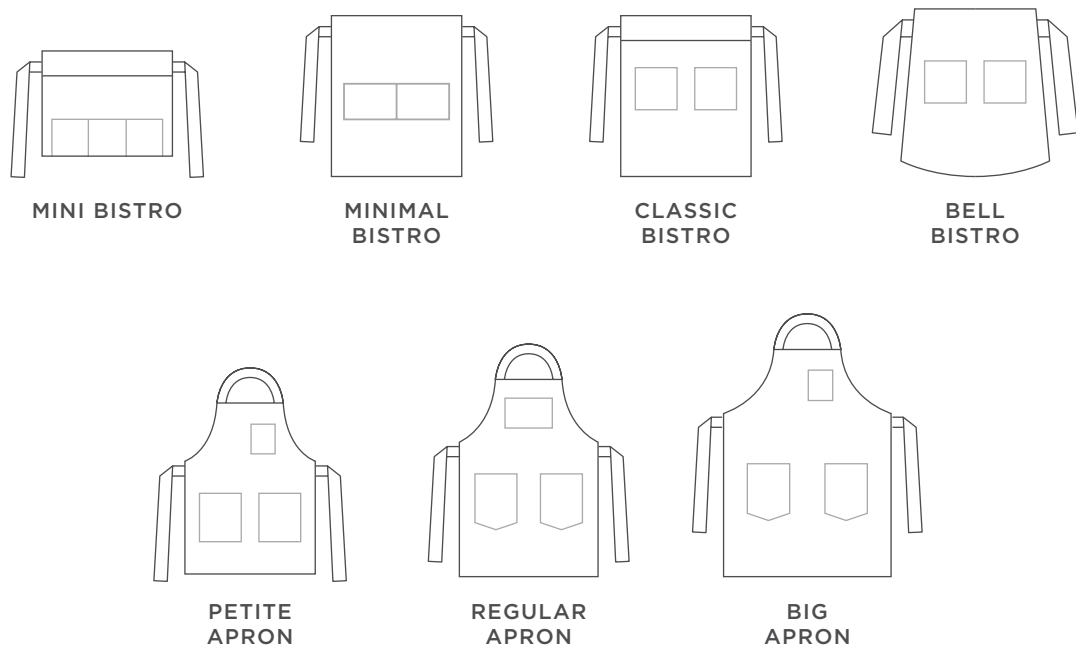

STEP 2 POCKETS

CHEST POCKETS



TOWEL LOOPS



LAP POCKETS



STEP 3 LOGO PLACEMENT



STEP 4 HARDWARE

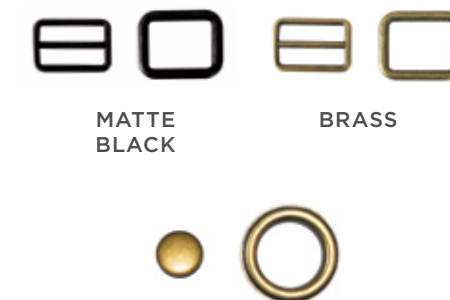

STEP 5 AMPERSAND



STEP 6 STRAPS



■ ADD-ONS

CROSSBACK STRAPS +\$10



FRONT

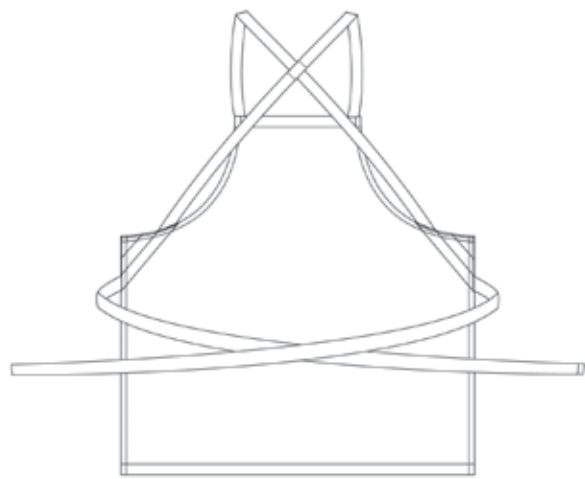

BACK

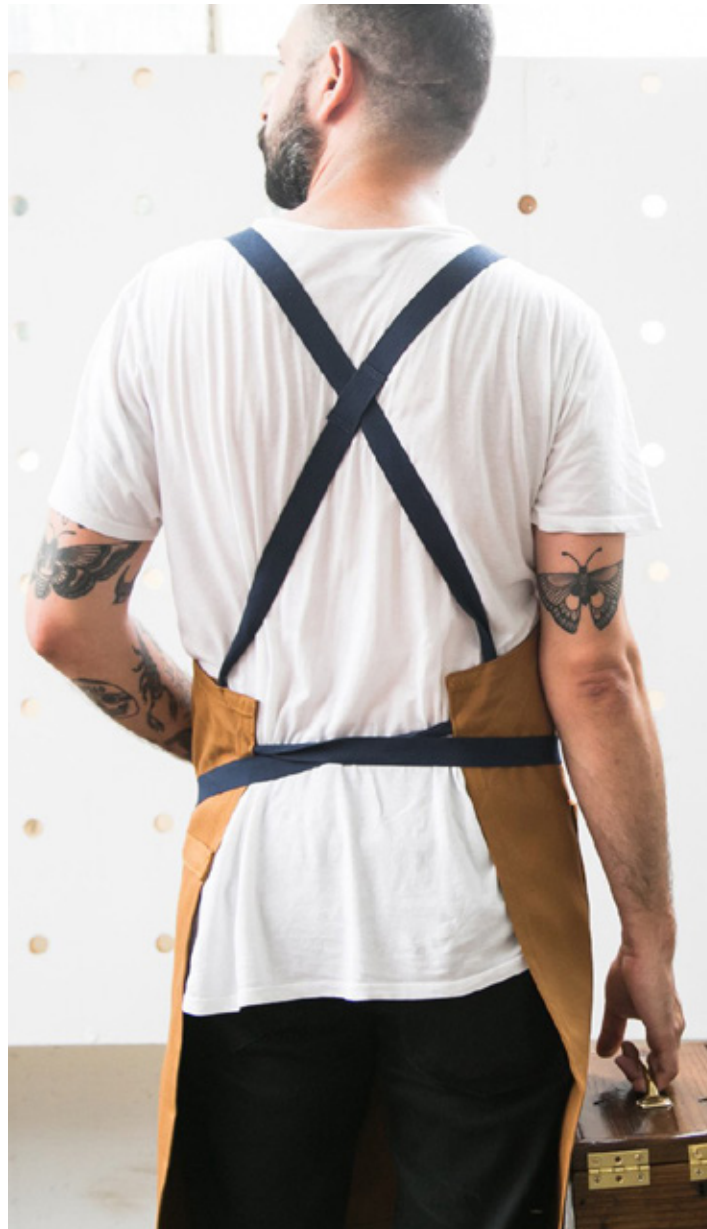

EMBROIDERY PLACEMENT

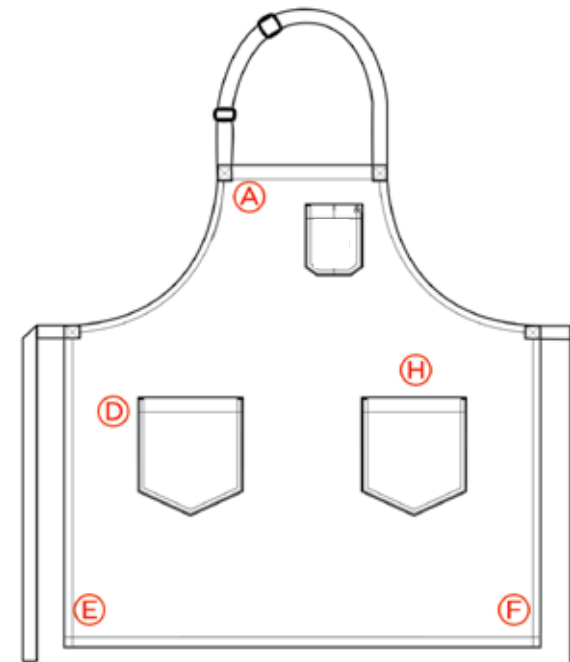

EMBROIDERY OPTIONS

BASIC +\$7

- Simple text or logo
- 1-2 colors
- Not filled in with color
- Smaller logos

DETAILED +\$9

- Minor details
- Multiple colors
- Not filled in with color
- Small to medium logos

INTRICATE +\$10 and up

- Fine details
- Lots filled in with color
- Multiple colors
- Medium to large logos

EMBROIDERY EXAMPLES

BASIC +\$7

RAINBOW
ROOM

DETAILED +\$9



INTRICATE +\$10 and up



CHEF COATS

Our chef coats were designed with mesh side panels, back venting for mobility, brass snap hardware and sleeve pen pockets. Ready to handle anything you've got.





» PEPPER CHEF COAT



» SALT BRASS CHEF COAT



WOMEN'S CHEF COATS

Our women's chef coat has the look and feel of a traditional chef coat but with an updated design that celebrates a woman's curves.

» MS. MARLIN WHITE 2.0



UNISEX CHEF COATS

An update on the classic snap-down coat, made with breathable twill and a modern collar. Available in all white, white & grey, and all black.

» SALT WHITE CHEF COAT



» MS. MARLIN BLUE 2.0



» MS. MARLIN BLUE 2.0

THE CHAMBRAY WORK SHIRT



»» COLLAR SNAP



»» CHAMBRAY SHORT SLEEVE



»» CHAMBRAY SHORT SLEEVE



»» CHAMBRAY LONG SLEEVE



CHEF SOCKS

Designed in partnership with sock makers Richer Poorer, we created a smart sock built to handle the hustle of chefs everywhere. The temperature-regulating technology is made to keep you cool, no matter how long the shift and how hot the kitchen.



THE KNIFE BAG REDEFINED

Made with American leather and a patent-pending grid system, the Mise bag allows you to customize the tools you need whether they're knives, scissors, tweezers, oyster shuckers or 20 spoons and a steel. Get your Mise en place and go.



1. Internal zipped pouch, made with water-resistant canvas
2. Handmade in Los Angeles
3. Securely fits up to a 300 mm knife
4. Military-grade nylon webbing
5. Slot for knife steel

6. Matte black American leather
 7. Specially designed grip-elastic straps
 8. Fits 6 knives*
 9. Gun-metal premium American-made zipper
 10. Red leather pull tab
 11. Reinforced threading
- *6 knife guards included

LIMITED EDITION COLLABORATIONS >>>

Like salt and pepper, magic happens when the right two things get together. That's why every year, we seek out brilliant collaborators to create unique, limited-edition products. Check out our website to see the latest.



^ H&B X THE HUNDREDS



^ H&B X BON APPÉTIT

“ We're not just talking any ol' apron. We collaborated with designers Hedley & Bennett for the Armani of aprons: crisp, American-milled light blue cotton with contrasting patriotic navy and red stitching around angled pockets and custom triangle accents. Top chefs across the globe wear H&B, so putting one on is basically like Superman slipping into his cape. *-Bon Appétit* ”



^ H&B X ALTON BROWN



^ H&B X JOY THE BAKER



^ H&B X GRAY MALIN



^ H&B X (RED)



^ H&B X RIFLE PAPER CO.

THE APRON SQUAD

Made by makers, for makers. H&B is more than just an apron company. We pride ourselves in the community we've created, with passion for our craft at the core.

SQUAD MEMBERS



^ JESSE TYLER FERGUSON



^ DANIELA SOTO INNES



^ EVAN FUNKE

BUSINESSES

FOOD & WINE

Google

Coca-Cola

SPACEX

S. PELLEGRINO

bon appétit

Tupperware

facebook

Delta

NIKE

AMERICAN EXPRESS

Blue Apron



^ JENI BRITTON BAUER



^ MARTHA STEWART



^ ROY CHOI

RESTAURANTS

SHAKE SHACK

ko

Hattie B's CHICKEN

PIG BLEECKER

jenis SPLENDID ICE CREAMS

EST. 1966 K-BOB'S STEAKHOUSE

SPORTELLO

milk momofuku milk bar

GIRL & THE GOAT

topolobampo

SPOON AND STABLE



^ AARON SILVERMAN



^ BROOKE WILLIAMSON



^ TIM HOLLINGSWORTH

A LETTER FROM OUR CEO

Since I started H&B five years ago as a line cook standing in my chef's kitchen, the goal was always bigger than just making aprons. It was about making people feel dignity and pride in the kitchen and helping them tap into their hustle to make those dreams come true.

Fast forward to today as I walk into our own factory in DTLA with our in-house sewing and production crew, customer service team sitting in treehouse offices, and marketing and sales squad all bustling to get the thousands of restaurants and businesses we outfit everything they need quickly, I can't help but smile.

To those of you who wear Hedley and Bennett and believe in our craftsmanship, I want to sincerely thank you with a big hug and a high five, and for those of you who aren't on the apron squad yet - what are you waiting for? The world needs more different, more uniqueness, more special in it, so let's get out there and deliver that to the world!!!!

xx Ellen Bennett



hedley & bennett

3864 South Santa Fe Ave
Vernon, CA 90058

TALK TO A HUMAN
(213) 744-1355

INSTAGRAM
[@hedleyandbennett](#)

FACEBOOK
[@hedleyandbennett](#)

EMAIL
orders@hedleyb.com

WEBSITE
www.hedleyandbennett.com